

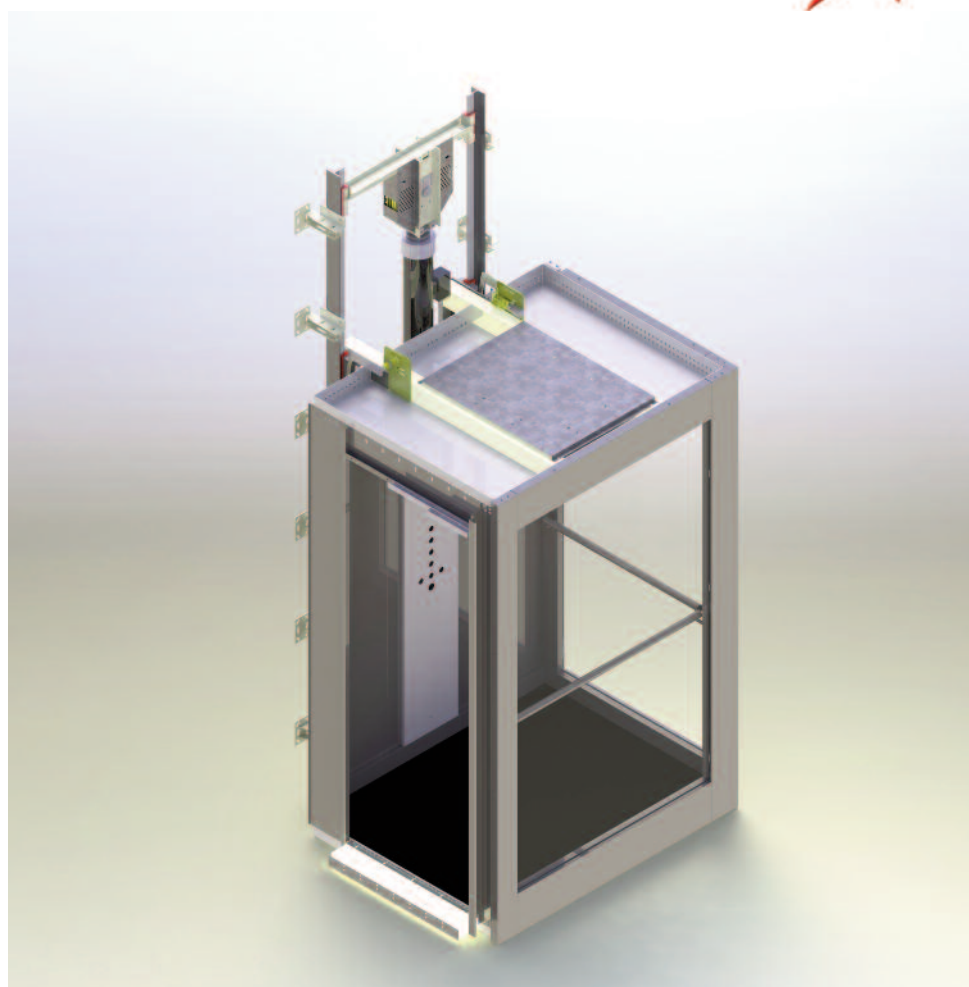

LIFT ACCORDING TO MACHINE DIRECTIVE
AUFZUG NACH MASCHINENRICHTLINIE

HHL W Line



EXCELLENCE IN COMPONENTS

- Ideal for removing architectural barriers in residential, office or public buildings
 - Optimal use of available space (headroom 2550 mm / pit 125 mm with rubber floor)
 - Plug-and-play system for fast and easy installation
 - Compact and silent hydraulic drive located inside the controller cabinet for easy access
 - Wide range of finishings to complement any interior design
 - Compliant with the requirements of the Machine Directive 2006/42/EC and the EN81-41
 - Optionally compliant with the requirements of the norms EN81-28 and EN81-70
- *Ideal zur Überwindung architektonischer Hindernisse im Wohnbereich, Büro oder öffentlichen Gebäuden*
 - *Optimale Raumausnutzung (Schachtkopf Minimum 2550 mm / Schachtgrube Minimum 125 mm)*
 - *"Plug-and-play" Montageprinzip ermöglicht eine schnelle und einfache Installation*
 - *Kompakter und geräuscharmer Hydraulikantrieb, leicht zugänglich im Steuerschrank*
 - *Verschiedenste gestalterische Ausführungen zur harmonischen Eingliederung in die Wohnraumgestaltung*
 - *Erfüllt die Anforderungen der Maschinenrichtlinie 2006/42/EG und der Norm EN81-41*
 - *Erfüllt wahlweise die Anforderungen der Normen EN81-28 und EN81-70*

LIFT ACCORDING TO MACHINE DIRECTIVE
AUFZUG NACH MASCHINENRICHTLINIE

HHL W Line



PRODUCT RANGE • PRODUKTIONSPROGRAMM

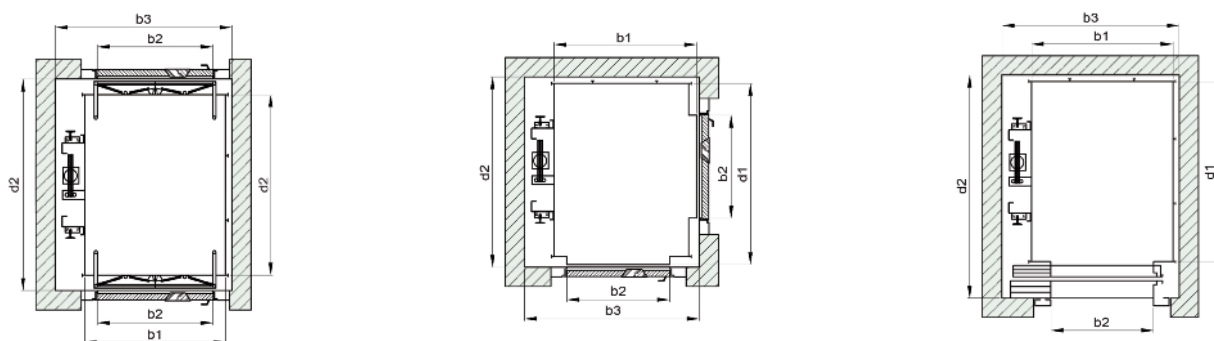

Car Door Type Türtyp Fahrkorb	Type (entrances) Typ (Eingänge)	Rated load Nennlast (max.) kg	Car internal width (50 mm steps) Lichte Fahrkorbbreite (Schritte je 50 mm)		Car internal depth (50 mm steps) Lichte Fahrkorbtiefe (Schritte je 50 mm)		Min. well width Min. Schachtbreite mm	Min. well depth Min. Schachttiefe mm	Max. clear opening Max. Türlichte mm	Norm Norm
			(min.) mm	(max.) mm	(min.) mm	(max.) mm				
Hydra 3 panels <i>Hydra (3-flüglig)</i>	1 - 0° / 180°	250	700	1100	900	1400	b1+280	d1+336	b1-100..200	EN81-41
		315								
		385								
	1 - 90°	250	850	1400	650	1100	b1+ 100	d1+516	b1-250	
		315								
		385								
	2 - 180°	250	700	1100	900	1400	b1+280	d1+572	b1-100..200	
		315								
		385								
2 - 90° / 270°	250	700	1100	900	1400	b1+516	d1+336	See tech. catalogue siehe techn. Katalog		
	315									
	385									
MDS1	1 - 0° / 180°	250	1000	1100	900	1400	b1 + 280 b1 + 300 for / für CO800	d1 + 290	b1-300	
		315								
		385								
	1 - 90°	250	1200	1400	650	1100	b1+ 100	d1 + 470	b1- 500	
		315								
		385								
	2 - 180°	250	1000	1100	900	1400	b1 + 280 b1 + 300 for / für CO800	d1 + 470	b1-300	
		315								
		385								
2 - 90° / 270°	250	1000	1100	1200	1400	b1 + 460 b1 + 480 for / für CO800	d1 + 290	See tech. catalogue siehe techn. Katalog		
	315									
	385									
BUS	1 - 0° / 180°	250	700	1100	850	1400	b1 + 280	d1 + 170	b1 - 100	
		315								
		385								
	1 - 90°	250	850	1400	650	1100	b1 + 100	d1 + 350	b1 - 100	
		315								
		385								
	2 - 180°	250	700	1100	850	1400	b1 + 280	d1 + 240	b1 - 100	
		315								
		385								
2 - 90° / 270°	250	750	1200	950	1500	b1 + 250	d1 + 170	b1 - 100		
	315									
	385									
No door keine Türe	1 - 0° / 180°	250	650	1100	950	1500	b1 + 280	d1 + 70	b1 - 50	
		315								
		385								
	1 - 90°	250	850	1400	750	1200	b1 + 100	d1 + 280	b1 - 50	
		315								
		385								
	2 - 180°	250	650	1100	1050	1600	b1 + 280	d1 + 40	b1 - 50	
		315								
		385								
2 - 90° / 270°	250	750	1200	950	1500	b1 + 250	d1 + 70	b1 - 150		
	315									
	385									

Car internal height Lichte Fahrkorbböhe	Min. headroom height (mm) Min. Schachtkopfhöhe	
	Hydra (3 panels) Hydra (3-flüglig)	MDS1/BUS/No door MDS1/BUS/keine Türe
mm		
2000	2650	2550
2100	2750	2650
2200	2850	2750

Min. pit depth	Min. Schachtgrubentiefe	mm
Rubber floor	Gummiboden	125
Granite	Granit	140